

# NEW RENAULT MASTER



**DRIVE THE CHANGE**



# FOR 111 YEARS, WE HAVE ALWAYS COMMUNICATED THE VIEW THAT FOR A VEHICLE TO BE IN TUNE WITH THE TIMES, IT HAS TO BE INNOVATIVE, MAKE A RESPONSIBLE COMMITMENT, AND INSPIRE PASSION WHILE OFFERING SUSTAINABLE MOBILITY FOR ALL.

Our relationship with drivers and their passengers is founded on one simple idea: for a car to be popular, it has to be practical, reliable and suited to the lifestyle and expectations of each individual. This is why Renault offers **general models, - cars for living -, accessible for everyone.** From the first standardised models in the beginning of the 20th century, to the upcoming launch of the first range of electric vehicles, **our aim has always been to make the motor car and mobility available to as many people as possible.**

Today, we are convinced **that another world is possible;** a world where the automobile is no longer a threat to the environment but instead combines **mobility, safety and quality - for everyone.**

We assert this vision every day, never losing sight of the fact **that passion for motoring is,** and will always be, what drives us forward.

We want to bring new meaning to the automobile, so that it can take a different, more appropriate position with regard to social issues and so that it will always remain a sign of progress for Mankind. **Starting next year there will be a groundbreaking range of electric vehicles, including a small van. They will be affordable to run - you will be able to drive up to 160 km using a battery that costs typically 2€ to charge (night time rate).**

The Renault vehicles for today and for the future are the founding stones of our **ambition to offer sustainable mobility to all.**

RENAULT. DRIVE THE CHANGE.



# CONTENTS



## **NEW MASTER**

DISCOVERY	02 > 03
DESIGN	04 > 05
ON-BOARD EXPERIENCE	06 > 07
STORAGE	08 > 09
FRONT AND REAR WHEEL DRIVE	10 > 11
FUEL CONSUMPTION & SAFETY	12 > 13

## **AS MANY MODELS AS PROFESSIONS**

PANEL VANS	14 > 15
CREW CAB & CHASSIS CAB	16 > 17

## **EQUIPMENT AND ACCESSORIES**

ADDITIONAL ADAPTATIONS & COMFORT	18 > 19
COLOURS, WHEELS & TECHNICAL FEATURES	20 > 21
EQUIPMENTS & OPTIONS	22 > 23

**NEW MASTER**  
**PRACTICAL, ROBUST AND ECONOMICAL.**  
**AN EXTRA WIDE RANGE...**  
**A MODEL FOR YOU**  
**WHATEVER YOUR NEEDS.**



**5**  
**YEARS**  
**UNLIMITED**  
**MILEAGE**  
**WARRANTY**

For your peace of mind, all RENAULT commercial vehicles are covered by a comprehensive warranty for 5 years without any mileage limitation.







## AN EXPRESSIVE DESIGN.

With its strong and dynamic front end, the New Master embodies efficiency. With its large headlights, a new grille and a wide bumper maximizing the bodywork protection, the New Master is modernity personified.



# A FULLY-FLEDGED WORKSPACE IN THE CAB.

Spacious, welcoming and comfortable, New Master's cab provides an optimal visibility, ergonomic controls, adjustable seat and steering wheel, air conditioning\*, improved noise insulation, the New Master has a raft of comfort-enhancing features normally associated with passenger cars. New Master also offers a built-in Carminat TomTom® navigation system\*\*, which guides you simply and easily to your destination (1). Renault has also equipped the New Master with both a retractable document holder\*\* on the dashboard and a swiveling desk on which to put your files or computer.

\*Available as an option  
\*\*Standard on Executive



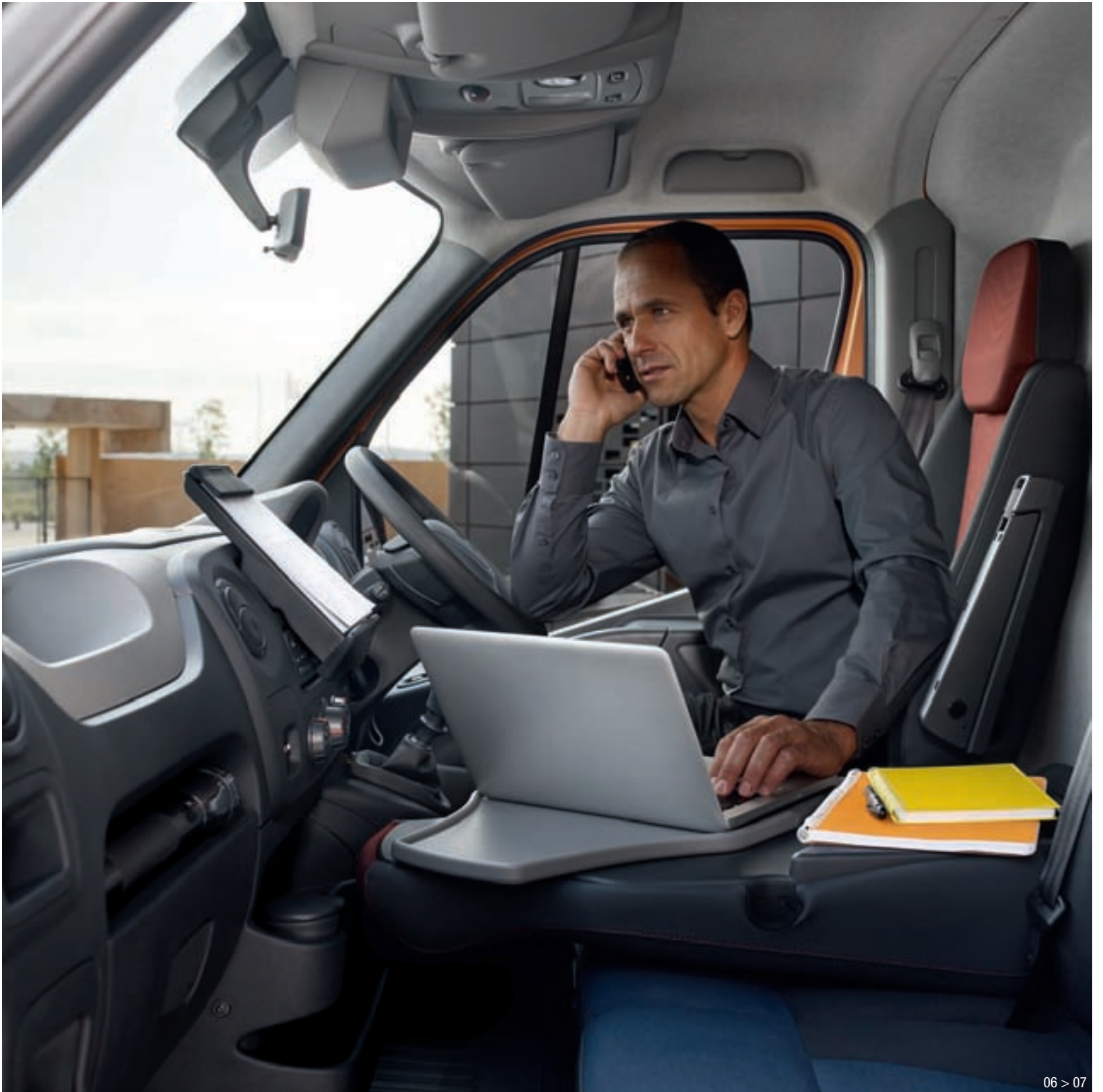

# MORE STORAGE FOR A BETTER ORGANISATION.

New Master has the market's most comprehensive range of storage solutions.

1. Swiveling desk on seatback rest\* - 2. Cup/can holders - 3. Overhead storage rack in cab - 4./7. Upper/Lower\*\* door pockets - 5. Under roof storage shelf at bulkhead - 6. Refrigerated glovebox - 8. Storage tray - 9. Storage under front passenger bench seat\*\* - 10. Retractable document holder \*\* - 11. Telephone holder and 12V power socket - 12. Cover on dashboard\*\*

\*As standard on Comfort    \*\*As standard on Executive

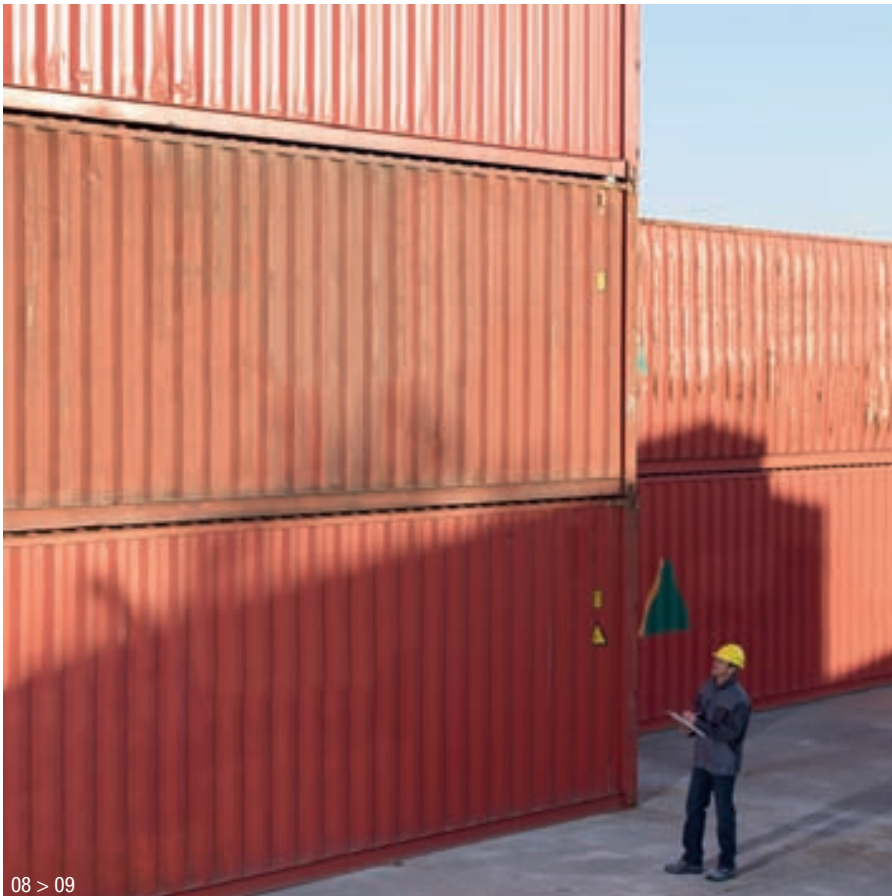

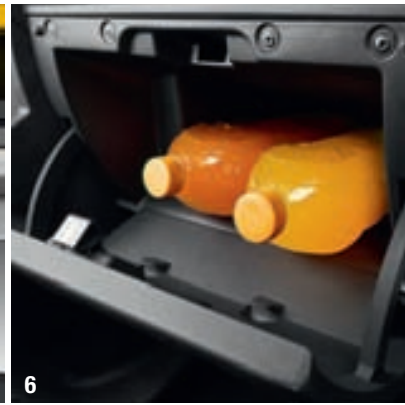

# FRONT AND REAR WHEEL DRIVE: FAR MORE POSSIBILITIES.

Strong and efficient, the New Master can adapt to the most demanding requirements. Need to carry heavy and bulky loads? No problem. The Rear Wheel Drive (RWD) variants ensure road handling designed to suit your professional needs. **Single wheels or twin wheels, the choice is yours.** Designed for operational use, **adaptive ESP and a rear step are fitted as standard on the panel vans.** The trailer towbar\* enables you to tow up to 3 tonnes.

\*Available as an option





# NEW MASTER WORK IN SAFETY.

To make your working day even easier and safer, the New Master has the best technology in terms of active and passive safety, such as:

- Adaptive ESP trajectory control (Electronic Stability Programme) comes as standard on the Rear Wheel Drive and optional on Front Wheel Drive\*, along with ASR traction control (1).
- ABS brakes with EBD (Electronic Brake Distribution) and Emergency Brake Assist as standard (2).
- Also standard are the driver's front airbag (3) and a full steel bulkhead (separating you from your load in the event of sudden braking).
- Passenger front and side airbag (3)\*\*\*.
- The new innovative Fixed Cornering Lamps option is exclusive in the market to New Master (4)\*\*\*.
- The Fog Lamps improve visibility in the event of fog or rain\*\*.
- Trip Computer indicates fuel consumption and maintenance parameters\*\*.
- Cruise control / speed limiter ensures a constant or limited speed according to your needs\*\*\*.

With New Master, you work in complete safety

\*Not available at launch    \*\*Standard on Executive    \*\*\*Available as an option

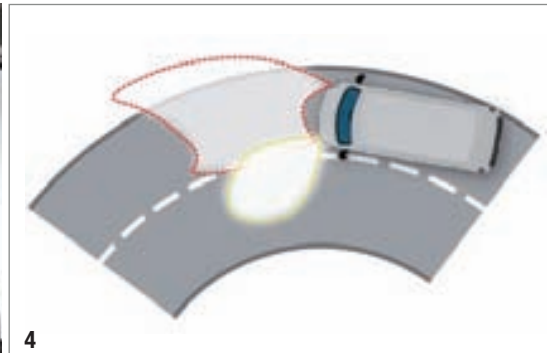
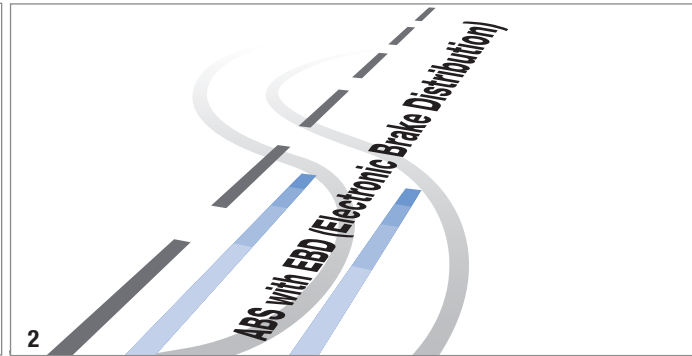
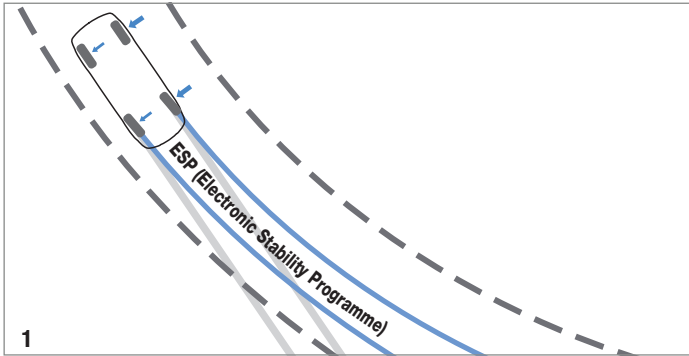

# NEW ENGINE: -1 L/100 KM\*

## MORE EFFICIENT, MORE ECONOMIC.

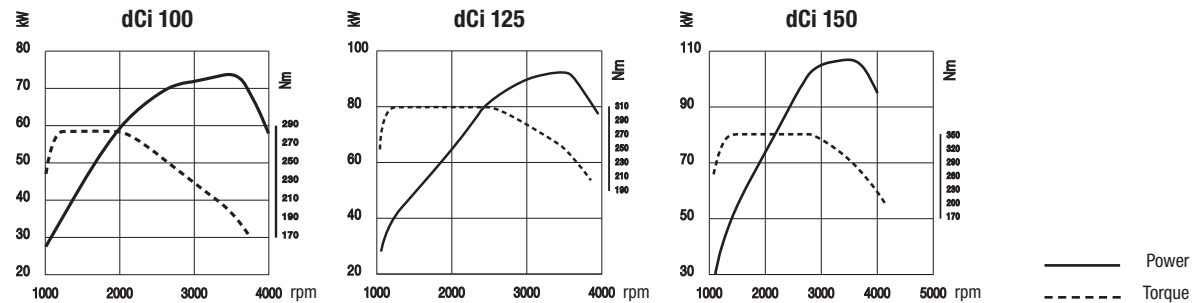

### ENGINES

The 2.3 l dCi Diesel engine on New Master, available in 100, 125 and 150 bhp versions, comes in front and rear wheel drive.



Front wheel drive engine



Rear wheel drive engine

The new engine offers you lower fuel consumption and lets you go further between refills. In addition, New Master pays particular attention to its maintenance costs, which are amongst the best on the market. Oil change frequency is taken to 40,000 km – 2 years (\*\*) and no need to plan a belt replacement, thanks to its lifetime-guaranteed timing chain.

(\*) Compared with the previous model of Master

(\*\*) On the first of the two terms reached

## FRONT WHEEL DRIVE PANEL VAN



All of the models share 5 essential requirements: robustness, agility, practicality, safety and onboard comfort. To meet your needs, the interior adaptations are infinite.

### WEIGHTS AND LOADS

	Loadspace (m <sup>3</sup> )	Max. payload (kg)		
		2.8t	3.3t	3.5t
<b>SL - SWB Low Roof *</b>	8	1,030	1,489	1,684
Max. load on Front axle (kg)		1,550	1,650	1,790
Max. load on Rear axle (kg)		1,650	1,900	2,100
Max. trailer weight (braked/unbraked) (kg)		2,500 / 750		
Turning circle, wall to wall		12.0m		
Turning circle, kerb to kerb		12.5m		

\*Not available at launch

	Loadspace (m <sup>3</sup> )	Max. payload (kg)	
		3.3t	3.5t
<b>MM - MWB Medium Roof</b>	10.8	1,415	1,610
Max. load on Front axle (kg)		1,650	1,790
Max. load on Rear axle (kg)		1,900	2,100
Max. trailer weight (braked/unbraked) (kg)		2,500 / 750	
Turning circle, wall to wall		13.6m	
Turning circle, kerb to kerb		14.1m	

	Loadspace (m <sup>3</sup> )	Max. payload (kg)
		3.5t
<b>LM - LWB Medium Roof</b>	13	1,530
<b>LH - LWB High Roof *</b>	14.8	1,508
Max. load on Front axle (kg)		1,790
Max. load on Rear axle (kg)		2,100
Max. trailer weight (braked/unbraked) (kg)		2,500 / 750
Turning circle, wall to wall		15.7m
Turning circle, kerb to kerb		16.2m

\*Not available at launch

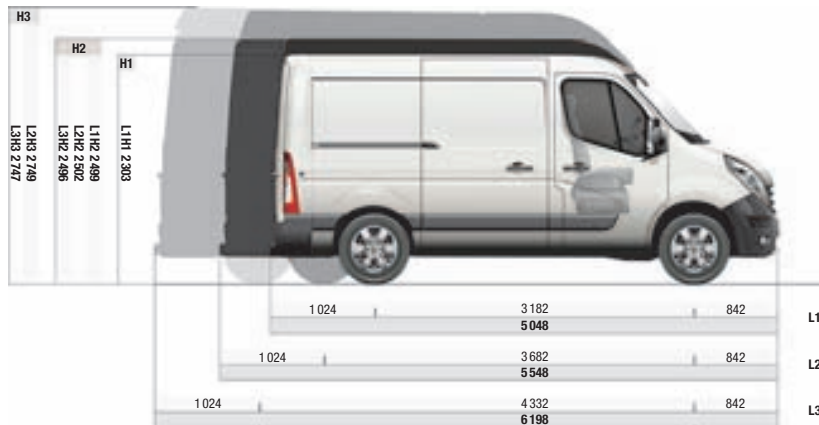

### INTERIOR DIMENSIONS

	SL	MM	LM	LH
<b>Loading area</b>				
Load length	2,583	3,083	3,733	3,733
Load length at 1.1m	2,530	3,030	3,680	3,680
Loadspace width	1,765	1,765	1,765	1,765
Loadspace width between wheel arches	1,380	1,380	1,380	1,380
Load height - floor to roof	1,700	1,894	1,894	2,144
<b>Sliding side door(s)</b>				
Width of sliding side door(s)	1,050	1,270	1,270	1,270
Height of sliding side door(s)	1,581	1,780	1,780	1,780

	SL	MM	LM	LH
<b>Rear door(s)</b>				
Width (169mm from the floor)	1,580	1,580	1,580	1,580
Door height	1,627	1,820	1,820	1,820
Loading sill	Min: 546 Max: 564	Min: 545 Max: 562	Min: 543 Max: 557	Min: 542 Max: 555
Min. ground clearance	182	174	172	169

3 Load Lengths: L1 = 2,583 mm  
L2 = 3,083 mm  
L3 = 3,733 mm

# REAR WHEEL DRIVE PANEL VAN



Strong and efficient, the New Master can adapt to the most demanding requirements. Need to carry heavy and bulky loads? No problem. The Rear Wheel Drive (RWD) variants ensure road handling designed to suit your professional needs. **Single wheels or twin wheels, the choice is yours.**

**SW = Single Wheels**  
**TW = Twin Wheels**

## WEIGHTS AND LOADS

	Loadspace (m <sup>2</sup> )	Max. payload (kg)	
		3.5t SW	3.5t TW
<b>MM L - MWB Medium Roof with Long rear overhang</b>	12.4	1,390	1,254
<b>MH L - MWB High Roof with Long rear overhang *</b>	14.2	1,362	-
Max. load on Front axle (kg)		1,790	1,790
Max. load on Rear axle (kg)		2,300	2,800
Max. trailer weight (braked/unbraked) (kg)		2,500 / 750	3,000 / 750
Turning circle, wall to wall		13.6m	
Turning circle, kerb to kerb		14.1m	

\*Not available at launch

	Loadspace (m <sup>2</sup> )	Max. payload (kg)	
		3.5t TW	4.5t TW
<b>LM L - LWB Medium Roof with Long rear overhang</b>	14.9	1,176	2,176
<b>LH L - LWB High Roof with Long rear overhang *</b>	17	1,151	2,151
Max. load on FR axle		1,790	1,790
Max. load on RR axle		2,800	3,200
Max. trailer weight (braked/unbraked) (kg)		3,000 / 750	
Turning circle, wall to wall		15.7m	
Turning circle, kerb to kerb		16.2m	

\*Not available at launch

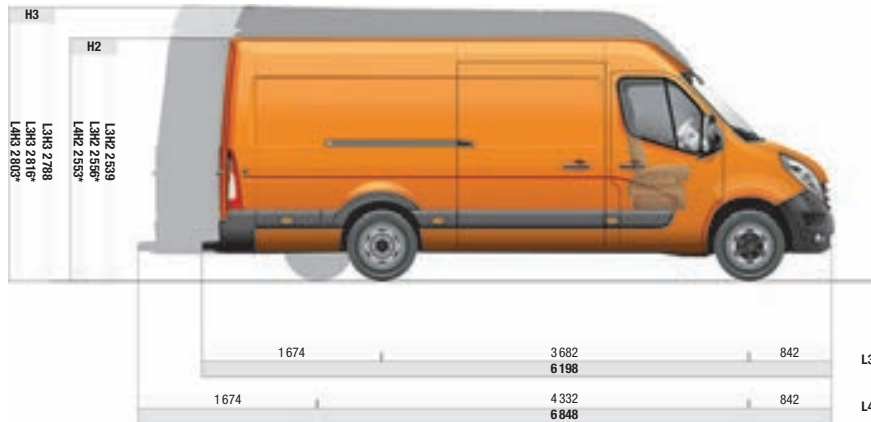

## INTERIOR DIMENSIONS

	MM L - SW	MM L - TW	MH L - SW	LM L - TW	LH L - TW
<b>Loading area</b>					
Load length	3,733	3,733	3,733	4,383	4,383
Load length at 1.1m	3,680	3,680	3,680	4,330	4,330
Loadspace width	1,765	1,765	1,765	1,765	1,765
Loadspace width between wheel arches	1,380	1,080	1,380	1,080	1,080
Load height - floor to roof	1,798	1,798	2,048	1,798	2,048
<b>Sliding side door(s)</b>					
Width of sliding side door(s)	1,270	1,270	1,270	1,270	1,270
Height of sliding side door(s)	1,684	1,684	1,684	1,684	1,684

	MM L - SW	MM L - TW	MH L - SW	LM L - TW	LH L - TW
<b>Rear door(s)</b>					
Width (169mm from the floor)	1,580	1,580	1,580	1,580	1,580
Door height	1,724	1,724	1,724	1,724	1,724
Loading sill	Min: 674 Max: 696	Min: 706 Max: 724	Min: 672 Max: 694	Min: 701 Max: 717	Min: 700 Max: 715
Min. ground clearance	197	181	197	167	167

SW: single wheels TW: twin wheels

2 Load Lengths: L3 = 3,733 mm  
L4 = 4,383 mm

## CREW CAB



New Master crew cab can transport up to 7 people and maintain a large loading area.

### WEIGHTS AND LOADS

	Loadspace (m³)	Max. payload (kg)
		3.5t
LM - LWB Medium Roof - Front wheel drive	9	1,365
MM L - MWB Medium Roof with Long rear overhang - Rear wheel drive - Single Wheels	8.3	1,365

### INTERIOR DIMENSIONS

	Front Wheel Drive LM - LWB Medium Roof	Rear Wheel Drive - Single Wheels MM L - MWB Medium Roof with Long rear overhang
<b>Loading area</b>		
Load length at 0.4m	2,825	2,825
Load length at 1m	2,640	2,640
Loadspace width	1,765	1,765
Loadspace width between wheel arches	1,380	1,380
Load height - floor to roof	1,894	1,798
<b>Sliding side door(s)</b>		
Width of sliding side door(s)	1,270	1,270
Height of sliding side door(s)	1,820	1,684
<b>Rear door(s)</b>		
Width at the lower part	1,580	1,580
Height	1,820	1,724
Loading sill (min./max.)	543 / 557	674 / 696
Ground clearance	172	197

### FRONT WHEEL DRIVE

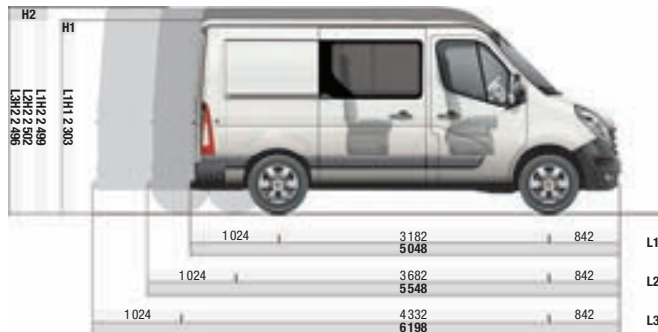

### REAR WHEEL DRIVE

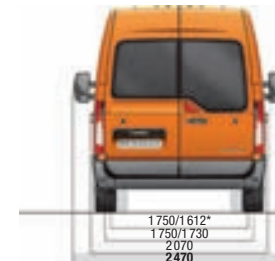
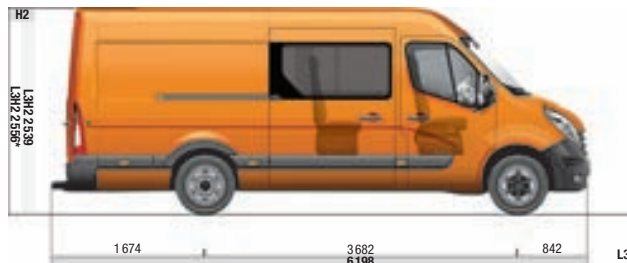

# CHASSIS CAB (SINGLE / DOUBLE)\*

With unfailing solidity, it is designed to receive a multitude of adaptations to suit precisely your needs.

\*Not available at launch

## FRONT WHEEL DRIVE

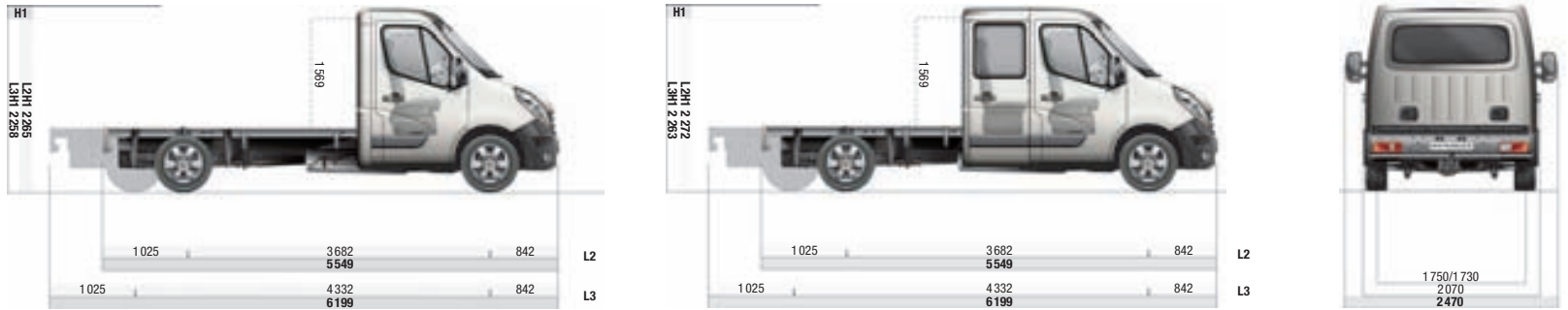

## REAR WHEEL DRIVE

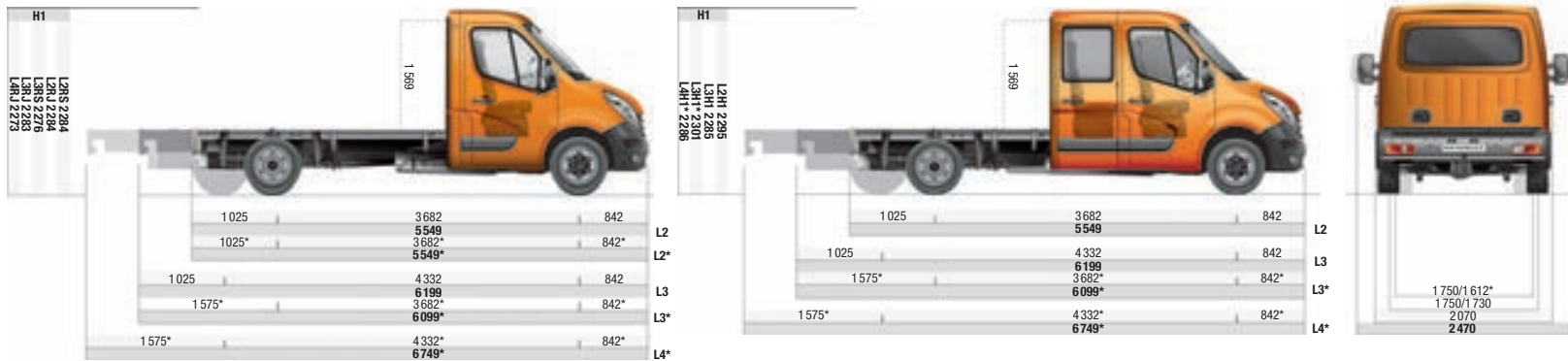

## SINGLE CABIN WEIGHTS AND LOADS

	Front Wheel Drive	Rear Wheel Drive
	MWB	LWB
	3.5t	3.5t SW
Max. payload (kg)	1,814	1,640
Max. load on front axle (kg)	1,790	1,790
Max. load on rear axle (kg)	2,100	2,300
Max. trailer weight (kg)	2,500/750	2,500/750
Turning circle, wall to wall	13.6m	15.7m
Turning circle, kerb to kerb	14.1m	16.2m

## SINGLE CAB DIMENSIONS

	Front Wheel Drive	Rear Wheel Drive
	MWB	LWB
Max. overall length	5,924	8,206
Overall cargo length (min./max.)	3,182/3,464	3,832/5,746
Loading sill height (min./max.)	735/740	771/775
Overall width with extended rear-view mirrors	2,654	2,654
Min. ground clearance	166	166

## DOUBLE CABIN WEIGHTS AND LOADS

	Front Wheel Drive	Rear Wheel Drive
	MWB	LWB
	3.5t	3.5t SW
Max. payload (kg)	1,615	1,447
Max. load on front axle (kg)	1,790	1,790
Max. load on rear axle (kg)	2,100	2,300
Max. trailer weight (kg)	2,500/750	2,500/750
Turning circle, wall to wall	13.6m	15.7m
Turning circle, kerb to kerb	14.1m	16.2m

## DOUBLE CAB DIMENSIONS

	Front Wheel Drive	Rear Wheel Drive
	MWB	LWB
Max. overall length	5,643	8,206
Overall cargo length (min./max.)	2,432/2,432	3,082/4,996
Loading sill height (min./max.)	727/732	765/768
Overall width with extended rear-view mirrors	2,654	2,654
Min. ground clearance	169	197

SW: single wheels TW: twin wheels

# COMFORT AND TECHNOLOGY

## 1. CARMINAT TOMTOM®

New Master offers Carminat TomTom®, the first truly affordable built-in navigation system. With calculation of the best route, real time traffic information and fixed speed camera warnings, all information is attractively displayed on the large colour screen which swivels to face the driver.

Its remote control provides intuitive, safe access to the various functions. This equipment saves time and reduces your fuel consumption.



1

## 2. KEY WITH HANDS-FREE ACCESS

Simply carry the hands-free access badge on you. The doors are opened by simply pushing the door handle without using the key.



2

3

## 3. 3-BUTTON KEY

Used to open/close the opening panels remotely, independently of the front and rear zones.

## 4. MANUAL AIR-CONDITIONING

## 5. REGULATED AIR-CONDITIONING

Adjustment of the desired temperature and electronic displays, rapid demisting and sun sensor.

## 6. CD MP3 BLUETOOTH® AUTORADIO\*

Reads mp3 files, its functionality also enables the hands-free kit to be connected so you can be contacted at any time.

## 7. PLUG&MUSIC CONNECTION

Hook up your digital, personal music player using the USB and iPod outlets and manage the system through steering wheel controls.

\* It is recommended not to drive when calling (please check your phone availability).



4



5



6



7



# ADDITIONAL ADAPTATIONS

## 1. 270° REAR STEEL DOORS

This 270° opening enables easy coupling on a logistics platform. Once open, the door is held in place by a magnet.



## 2. ANTI-SLIP PLYWOOD FLOOR

Protects the loading area floor of your New Master when transporting merchandise.



## 3. ENTIRE WOOD PROTECTION

Protect the entire loading area of your New Master when transporting merchandise.



## 4. ALUMINIUM ROOF RACK + WALK-WAY

Specially designed for New Master, the aluminium roof rack is fitted with a roller at the rear to facilitate loading. Also available with a steel ladder and a walk-way.



## 5. DIFF" LOCK

Improves mobility on slippery or loose surfaces, for example for use on worksites.



## 6/7. ENGINE POWER TAKE-OFF & GEARBOX POWER TAKE-OFF

Used to recover engine power (directly or via the gearbox) to operate equipments such as refrigerating units, cranes and hydraulic arms.

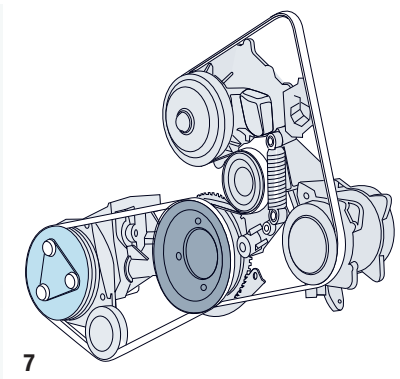

## 8. 12V OUTLET IN LOADSPACE

New - enables electric tools to be used in the loading area.

# COLOURS

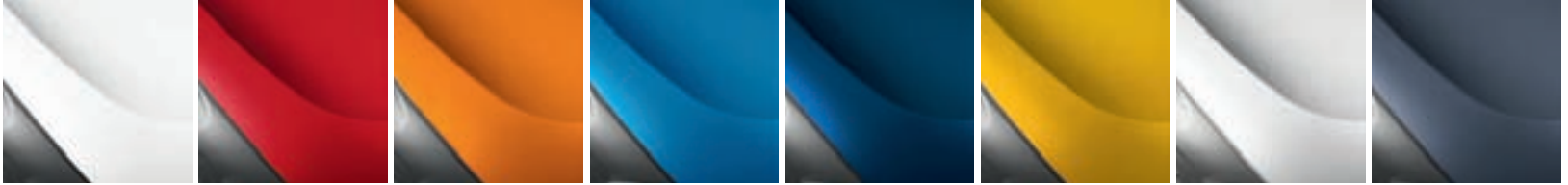

GLACIER WHITE (389)

CARMEN RED (719)

TANGERINE ORANGE (031)

SLATE BLUE (423)

VOLGA BLUE (RNQ)

ACID YELLOW (OV 396)

STAR SILVER (TE KNH)

BLUE GREY (TE J47)

\* Business variants does not include: ACID YELLOW, STAR SILVER, or BLUE GREY

## Non-metallic

## Metallic

Glacier White  
(389)

Carmen Red  
(719)

Tangerine Orange  
(031)

Slate Blue  
(423)

Volga Blue  
(RNQ)

Acid Yellow  
(OV 396)

Star Silver  
(TE KNH)

Blue Grey  
(TE J47)



# HUBCAPS AND WHEEL RIMS



MINI WHEEL STYLERS  
(AS STANDARD ON BUSINESS)



SMALL WHEEL STYLERS  
(AS STANDARD ON COMFORT)



MAXI WHEEL STYLERS  
(AS STANDARD ON EXECUTIVE)



MAXI WHEEL STYLERS  
(AS STANDARD ON EXECUTIVE -  
REAR WHEEL DRIVE / SINGLE WHEELS)



16" ALLOY WHEELS  
(FWD VARIANTS ONLY)

# UPHOLSTERY



1. KALEIDO (DARK GREY) UPHOLSTERY

2. VINYL UPHOLSTERY

# TECHNICAL FEATURES

Engines	Euro 4 Manual Gearbox			Euro 5 Robotized Gearbox	
	dci 100 bhp	dci 125 bhp	dci 150 bhp *	dci 125 bhp *	dci 150 bhp *
Depollution level	Euro 4	Euro 4	Euro 4	Euro 5	Euro 5
Max. power KW (hp) at rpm	74 (100) / 3500	92 (125) / 3500	107 (145) / 3500	92 (125) / 3500	107 (145) / 3500
Max. torque (Nm) at rpm	285	310	350	310	350
Cylinders / capacity (cm³)	2298	2298	2298	2298	2298
Number of cylinders per valves	4/16	4/16	4/16	4/16	4/16
Turbo (fixed geometry / variable)	FGT	FGT	VGT	FGT	VGT
Particules filter	No	No	No	Yes	Yes
Fuel tank capacity (in litres)	105 (80 optional)	105 (80 optional)	105 (80 optional)	105 (80 optional)	105 (80 optional)
<b>FWD PANEL VANS</b>					
SL28 - SWB Low Roof 2.8t	●	-	-	-	-
SL33 - SWB Low Roof 3.3t	●	-	-	-	-
SL35 - SWB Low Roof 3.5t	●	●	-	-	-
MM33 - MWB Medium Roof 3.3t	●	-	-	-	-
MM35 - MWB Medium Roof 3.5t	-	●	-	-	-
LM35 - LWB Medium Roof 3.5t	-	●	●	●	-
LH35 - LWB High Roof 3.5t	-	●	●	-	-
<b>RWD PANEL VANS</b>					
MM L 35 SW - MWB Medium Roof with Long rear overhang 3.5t Single Wheels	-	●	●	-	●
MM L 35 TW - MWB Medium Roof with Long rear overhang 3.5t Twin Wheels	-	●	●	-	-
MH L 35 SW - MWB High Roof with Long rear overhang 3.5t Single Wheels	-	●	●	-	-
LM L 35 TW - LWB Medium Roof with Long rear overhang 3.5t Twin Wheels	-	●	●	-	-
LH L 35 TW - LWB High Roof with Long rear overhang 3.5t Twin Wheels	-	●	●	-	-
LM L 45 TW - LWB Medium Roof with Long rear overhang 4.5t Twin Wheels	-	●	●	-	-
LH L 45 TW - LWB High Roof with Long rear overhang 4.5t Twin Wheels	-	●	●	-	-
<b>CREW CAB</b>					
LM35 - LWB Medium Roof 3.5t	-	●	-	-	-
MM L 35 SW - MWB Medium Roof with Long rear overhang 3.5t Single Wheels	-	●	-	-	-
<b>CHASSIS CAB</b>					
M35 - MWB 3.5t	-	●	-	-	-
L35 SW - LWB 3.5t Single Wheels	-	●	●	-	-
<b>CHASSIS CREW CAB</b>					
M35 - MWB 3.5t	-	●	-	-	-
L35 SW - LWB 3.5t Single Wheels	-	●	●	-	-

TW: twin wheels SW: single wheels \* Start of sales at a later date

# FUEL CONSUMPTION

Fuel consumption in l/100km	Euro 4 Manual Gearbox	
	dci 100 bhp & dci 125 bhp	dci 150 bhp *
<b>FRONT WHEEL DRIVE</b>		
Urban cycle	9.2 / 10.6	
Extra-urban cycle	6.9 / 8.6	
Mixed cycle	7.8 / 9.3	
CO <sub>2</sub> emissions (g/km)	203 / 251	
<b>REAR WHEEL DRIVE</b>		
Urban cycle	10.1 / 10.6	
Urban cycle	8.4 / 9.4	
Mixed cycle	9.2 / 9.4	
CO <sub>2</sub> emissions (g/km)	243 / 249	



## 1. 6-SPEED MANUAL GEARBOX

Fitted as standard on all New Master engines. It allows the entire load capacity to be used with good reaction on the intermediate gears. The 6<sup>th</sup> gear reduces noise and fuel consumption at high speeds.

## 2. 6-SPEED AUTOMATIC ROBOTIZED GEARBOX

In automatic or pulse mode, it increases the driving comfort.

# EQUIPMENT AND OPTIONS

	Business ***	PANEL VAN & CREW CAB Comfort	Executive	CHASSIS CAB & CHASSIS CREW CAB Comfort	Executive
<b>EXTERIOR</b>					
Side protection strips	●	●	●	-	-
Rear bumpers	●	●	●	-	-
Front mudflaps	-	-	-	○	○
Front & rear mudflaps	-	○	○	○	○
Rear step (as an option on FWD)	-	●/○	●/○	-	-
Mini wheel stylers	●	-	-	-	-
Small wheel stylers	-	●	-	●	-
Maxi wheel stylers	-	-	●	-	●
16" alloy wheels (FWD variants only)*	-	○	○	○	○
Metallic paint	-	○	○	○	○
<b>DOORS AND WINDOWS</b>					
Rear steel doors with 180° opening	●	●	○	-	-
Rear glazed doors with 180° opening	-	○	○	-	-
Rear steel doors with 270° opening	-	○	●	-	-
Rear glazed doors with 270° opening	-	○	○	-	-
Left hand sliding door (unglazed) (glazed on Crew Cab)	-	●	●	-	-
Left hand sliding door with fixed window	-	○	○	-	-
Left hand sliding door with opening window*	-	○	○	-	-
Right hand sliding door (unglazed) (not on Crew Cab)	-	○	○	-	-
Right hand sliding door with fixed window	-	○	○	-	-
Right hand sliding door with opening window*	-	○	○	-	-
Heated rear windows	-	○	○	-	-
Manual front windows	●	-	-	-	-
Electric front windows	-	●	-	●	-
One touch electric front windows	-	-	●	-	●
<b>BULKHEADS</b>					
Full steel bulkhead (glazed on Crew Cab)	●	●	●	-	-
Full (glazed) bulkhead	-	○	○	●	●
Full (glazed) bulkhead with mesh (not on Crew Cab)	-	○	○	-	-
<b>SAFETY</b>					
ABS with EBD (Electronic Brake Distribution)	●	●	●	●	●
ESP* (available later as an option on FWD variants)	-	●/○	●/○	●/○	●/○
Front driver's airbag	●	●	●	●	●
Side driver's airbag	-	○	○	○	○
Front passenger's airbag*	-	○	○	○	○
Front and side passenger's airbags + single passenger seat* (not on Crew Cab)	-	○	○	○	○
Manual key	●	-	-	-	-
2 button key	-	●	-	●	●
3 button key with selective opening	-	-	●	-	-
Additional key	-	○	○	○	○
Key with hands-free access	-	○	○	○	○
Central Deadlocking	-	●	●	●	●
Alarm (not on Crew Cab)	-	○	○	○	○
Alarm pre-equipment (for after sales fitting) (only on Crew Cab)	-	○	○	-	-
Repairing kit	●	-	-	-	-
Spare wheel under body	-	●	●	●	●
<b>VISIBILITY</b>					
Double optic front headlamps	●	●	●	●	●
Fog lamps	-	○	●	○	●
Fixed cornering lamps (+ESP)	-	○	○	○	○
Automatic headlamps and front windscreen wipers (light and rain sensitive sensors)	-	○	○	○	○
Manual rear-view mirrors	●	-	-	-	-
Electric rear-view mirrors	-	●	●	●	●
Extended rear-view mirrors	-	-	-	○	○
<b>DRIVING</b>					
Power steering	●	●	●	●	●
Speed changing signal lamp (ex: from 3 <sup>rd</sup> speed to 4 <sup>th</sup> speed)	●	●	●	●	●
Trip computer	-	○	●	○	●
Cruise control / speed limiter	-	○	○	○	○
Parking proximity sensor	-	○	○	-	-
Reverse camera	-	○	○	-	-
Parking proximity sensor + reverse camera	-	○	○	-	-
Digital tachograph (mandatory for 4.5t variants)	-	○	○	○	○
Diff <sup>l</sup> lock (RWD only)	-	○	○	○	○
<b>COMFORT</b>					
Front manual air conditioning	-	○	○	○	○
Air conditioning with climate control	-	○	○	○	○
Manual front windscreen wipers	●	●	●	●	●
<b>AUDIO / NAVIGATION</b>					
Radio MP3 CD with separate display & RCA Outlet	-	●	-	●	-
Radio MP3 CD with separate display & RCA Outlet + Bluetooth	-	○	●	○	●
Radio MP3 CD with separate display & RCA Outlet + Bluetooth + Plug & Music (USB & iPod®)	-	○	○	○	○
Carminat TomTom® navigation system (Ireland map)	-	○	●	○	●
European map upgrade	-	○	○	○	○

	Business ***	PANEL VAN & CREW CAB Comfort	Executive	CHASSIS CAB & CHASSIS CREW CAB Comfort	Executive
<b>STORAGE</b>					
4 Cup/can holders	●	●	●	●	●
Swivelling desk on seat backrest (requires unfixed passenger bench seat)	-	●	●	●	●
Overhead storage rack in cab	●	●	●	●	●
Under roof storage shelf at bulkhead	●	●	●	-	-
Refrigerated glove box	●	●	●	●	●
Storage tray	●	●	●	●	●
Under-seat storage (standard with 3 <sup>rd</sup> type passenger bench seat)	-	●	●	●	●
Money, phone and card storage	●	●	●	●	●
2 x 12 V outlets on dashboard	●	●	●	●	●
Retractable document holder	-	-	●	-	●
Cover on dashboard	-	-	●	-	●
Driving/sun glasses holder on driver side	-	-	●	-	●
Lower door storage	-	-	●	-	●
<b>LOADSPACE</b>					
Floor anchorage points in the load area (SWB: 8, MWB: 10, LWB:12)	-	●	●	-	-
Side anchorage points in the load area (8)	-	○	●	-	-
Anti-slip plywood floor*	-	○	○	-	-
Entire wood protection + anti-slip plywood floor*	-	○	○	-	-
Half height plyside panels*	-	○	○	-	-
12V outlet	-	○	●	-	-
<b>SEATS</b>					
Driver's seat with armrest	-	●	●	●	●
Driver's seat with lumbar adjustment	-	●	●	●	●
Driver's seat with fully adjustable suspension type	-	○	○	○	○
Front passenger's single seat	-	○	○	○	○
2 seaters front passenger fixed benchseat	●	-	-	-	-
2 seaters front passenger benchseat with swivelling desk on seat backrest	-	●	-	●	-
2 seaters front passenger benchseat with swivelling desk on seat backrest & underseat storage	-	○	●	○	●
Vinyl upholstery	-	○	○	○	○
<b>ADAPTATIONS</b>					
Aluminium roof rack (not available on high roof variants)* (not on Crew Cab)	-	○	○	-	-
Aluminium roof rack + walk-way (not available on high roof variants)* (not on Crew Cab)	-	○	○	-	-
Roof bars (not available on high roof variants)* (not on Crew Cab)	-	○	○	-	-
Steel ladder (not available with 270° rear doors)* (not on Crew Cab)	-	○	○	-	-
Tow bar (available later on RWD)	-	○	○	○	○
Engine power take-off	-	○	○	○	○
Gearbox power take-off (RWD only)	-	○	○	○	○
Battery interface	-	○	○	○	○
B pillar wiring connection point (not on Chassis Crew Cab)	-	-	-	○	○
Conversion interface box	-	○	○	○	○
Increased idle speed	-	○	○	○	○
Long wiring loom	-	-	-	○	○
Side marker lights (mandatory for 6m length)	-	○	○	○	○
80 litre fuel tank	●	○	○	○	○
105 litre fuel tank	-	●	●	●	●

●: Standard ○: Optional - : Not available \* Not available at launch

## EQUIPMENTS LEVELS

<b>Standard equipments ***</b>			
ABS with EBD (Electronic Brake Distribution)	"Kaleido" upholstery (dark grey)	80 litre fuel tank	<b>BUSINESS</b>
Front driver's airbag	Mini wheel stylers	Manual rear-view mirrors	
2 seaters front passenger fixed benchseat	Repairing kit	16" steel wheels	
Manual heating	Manual front windows	Manual key	
Full steel bulkhead	Rear steel doors with 180° opening		
<b>Additional standard equipment = Business +</b>			
Driver's seat with armrest	Radio MP3 CD with separate display & RCA Outlet	ESP (standard on RWD / available later as an option on FWD variants)	<b>COMFORT</b>
Driver's seat with lumbar adjustment	Electric front windows	Small wheel styler	
2 seaters front passenger benchseat with swivelling desk on seat backrest	Electric rear-view mirrors	Floor anchorage points in the load area (SWB: 8, MWB: 10, LWB:12)	
Left hand sliding door (unglazed)	Normal size spare wheel (under body)	105 litre fuel tank	
Central Deadlocking	Smocker pack	2 button key	
<b>Additional standard equipment = Comfort +</b>			
Trip computer	Rear steel doors with 270° opening	Lower door storage	<b>EXECUTIVE</b>
2 seaters front passenger benchseat with swivelling desk on seat backrest & underseat storage	12V outlet in the load area	Driving/sun glasses holder on driver side	
Large wheel stylers	Fog lamps	3 button key with selective opening	
One touch electric front windows	Side anchorage points in the load area (8)	Retractable document holder	
Carminat TomTom® navigation system (Ireland map)	Radio MP3 CD with separate display & RCA Outlet + Bluetooth		
	Cover on dashboard		

\*\*\* only available on SL - SWB Low Roof - 2.8t



# Paralympic Council of Ireland

Official sponsor of 2012 Irish Paralympic Team

Driving Success Towards London 2012 Paralympic Games

# WHO BETTER THAN RENAULT TO SERVICE YOUR RENAULT?

## I – THE RENAULT CUSTOMER CARE PACKAGE: YET ANOTHER OF THE PLEASURES OF RENAULT OWNERSHIP

Today's Renault cars testify to the enormous technological advances made over the past decade and demonstrate the benefits which those advances have brought to the motorist. The modern Renault performs more strongly, uses less fuel and is safer than ever before. Equally importantly, it is unprecedentedly durable and reliable - a fact which is reflected in the remarkable warranty package enjoyed by every Renault owner. All Renault vehicles come with 3 years warranty and AA Roadside Assist. In the case of your New Master, this warranty package is extended up to 5 years and unlimited mileage\*. Paintwork is also guaranteed for 3 years while the anticorrosion warranty runs for 6 years.

## II – A COMPREHENSIVE RANGE OF PRACTICAL, HELPFUL SERVICES

### **Renault Roadside Assistance**

The support you get in the 5 years of owning your new Renault is enhanced by free Renault Assistance cover. The Renault Assistance team is there for the sole purpose of responding to emergency calls from Renault customers, so you can be assured of top class service. Your handbook will give a complete rundown of all the help and services available to you, but, briefly, they include:

Roadside Assistance: if you breakdown or your car is immobilised, at any time of day or night, one free phone call will bring help.

Recovery: if your car can't be fixed by the side of the road, your vehicle will be recovered to the nearest Renault dealer and you will be offered an alternative form of mobility, if need be.

At home: you don't have to be out and about to get help. The Assistance provider will attend a breakdown at your home or office as well.

## III – SERVICES AVAILABLE FROM YOUR RENAULT DEALERSHIP

### **Superior cars – superior service**

Renault is represented by a nationwide network of dealers, so you can be sure that you're never far from a group of experts who can help you get the very most from ownership of your new car. Renault workshops are equipped with the very latest in diagnostic and other equipment to keep your car operating at peak efficiency. Your dealer's parts department houses a huge range of electrical and mechanical parts, so repair or servicing operations are hardly ever delayed by the lack of vital parts. Your local dealer is the first point of contact for anything and everything concerned with your new Renault - including, of course, a test drive!

The best accessory shop in town is at your Renault dealer. If you've looked at the specification lists in this brochure, you won't need to be told that Renault cars are amazingly well equipped. But Renault owners are individuals with their own individual tastes, needs and interests.

Which is why the Renault Boutique at Renault dealerships offers an enormous range of additional equipment and accessories. There are alloy wheels; body kits; carpet mats; sun blinds; tow bars; mudflaps; roof racks; plastic / wooden floors; alarm systems; integrated mobile phone system and much more besides. Every single item is made to the same quality standards as the components used in Renault cars themselves and is a perfect match for Renault's distinctive visual style.

## IV – CUSTOMER RELATIONS SERVICE

Renault knows the value of communicating with its customers and we have established effective ways of keeping in touch with you. Whatever your query you can contact Renault Ireland Customer Services Department on LoCall **1890 771 771**

You can also visit us on the Internet at [www.renault.ie](http://www.renault.ie)

Or write to us at:

Renault Ireland,  
Customer Services Department,  
Unit 39 Boeing Road,  
Airways Industrial Estate,  
Old Airport Road,  
Santry, Dublin 17  
LoCall: **1890 771 771**

\* 5 years / unlimited mileage package available at launch. Please check terms and conditions in your local dealership.

# NEW RENAULT MASTER



([www.renault.ie](http://www.renault.ie))

The utmost has been done to ensure that the content of this publication is accurate and up-to-date when going to press. This document has been created on the basis of pilot lots and prototypes. As part of its ongoing product improvement policy, Renault reserves the right to modify the specifications, vehicles and accessories described and shown at any time. Such modifications are communicated to Renault dealers as quickly as possible. Depending on the country of sale, certain versions may differ and certain equipment may be unavailable (as standard, optional or accessory). Please contact your nearest dealer for the latest information. For printing reasons, the colours which appear in this document may differ slightly from the actual paint and the upholstery colours. All rights reserved. It is forbidden to reproduce in any format and by any means all or part of this publication without prior written authorisation from Renault.